

DECK EYES CATALOGUE

Ocean Racers, Cruising and Metre Class Yachts



Timeless winches & fittings

ABSOLUTE

ROUND EYE PLUG



Round eye to be used with our deck plates.

Materials: bronze (CuAl10Ni) and stainless steel (316);

Finishes: polished bronze or chrome plated;

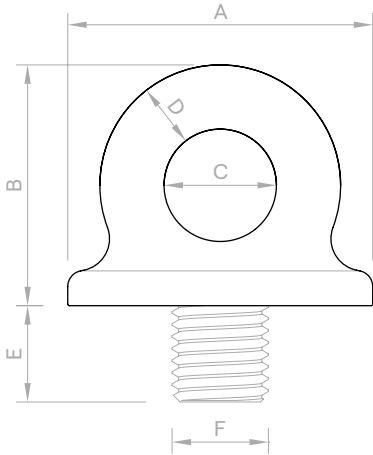

Part number	A mm	B mm	C Ø mm	D mm	E mm	F M
A001	38	30	14	8	16	M16
A002	57	45	21	12	20	M20
A003	76	60	28	16	24	M24
A004	95	75	35	20	30	M30
A005	114	90	42	24	36	M36
A006	133	105	49	28	42	M42
A007	152	120	56	32	48	M48

These are approximate measurements.

Note: Images shown are indicative only.

ROUND EYE



Round eye with outer bolts.

Materials: bronze (CuAl10Ni);

Finishes: polished bronze or chrome plated;

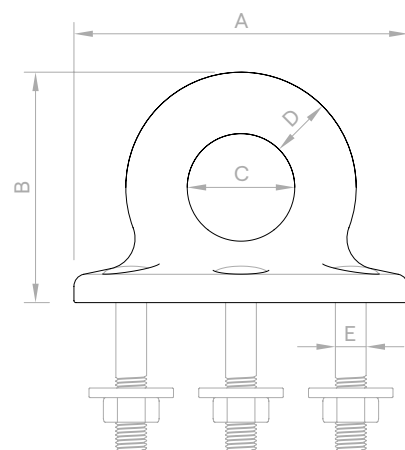

Part number	A mm	B mm	C Ø mm	D mm	E* M
A008	66	45	21	12	M6 (x6)
A009	88	60	28	16	M8 (x6)
A010	110	75	35	20	M10 (x6)
A011	132	90	42	24	M12 (x6)
A012	154	105	49	28	M16 (x6)
A013	176	120	56	32	M20 (x6)

These are approximate measurements.

* The fixing bolts are not included, they can be supplied if requested.

Note: Images shown are indicative only.

ROUND EYE (EXTENDED)



Round eye to be used with our deck plates.

Materials: bronze (CuAl10Ni) and stainless steel (316);

Finishes: polished bronze or chrome plated;

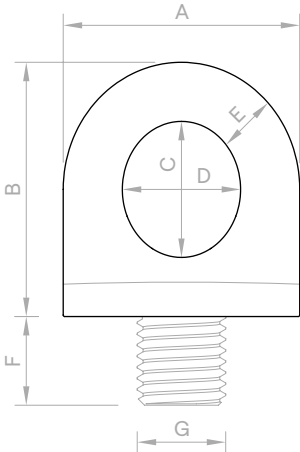

Part number	A mm	B mm	C mm	D mm	E mm	F mm	G M
A014	48	52	28	24	12	20	M20
A015	64	69	37	32	16	24	M24

These are all approximate measurements.

Note: Images shown are indicative only.

OVAL EYE

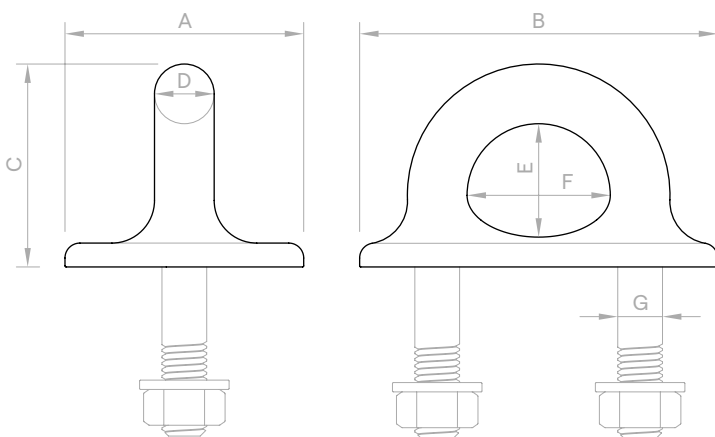

Oval eye with inner bolts.

Materials: bronze (CuAl10Ni) and stainless steel (316);

Finishes: polished bronze or chrome plated;

Part number	A mm	B mm	C mm	D mm	E mm	F mm	G* M
A016	48	72	29	41	12	23	M10 (x2)
A017	64	96	38	54	16	30	M12 (x2)
A018	80	120	48	68	20	38	M16 (x2)
A019	96	144	58	82	24	46	M20 (x2)
A020	112	168	67	95	28	53	M24 (x2)
A021	128	192	77	109	32	61	M30 (x2)

These are approximate measurements.

* Bolts are supplied with a standard length of 80mm.

Note: Images shown are indicative only.

OVAL EYE

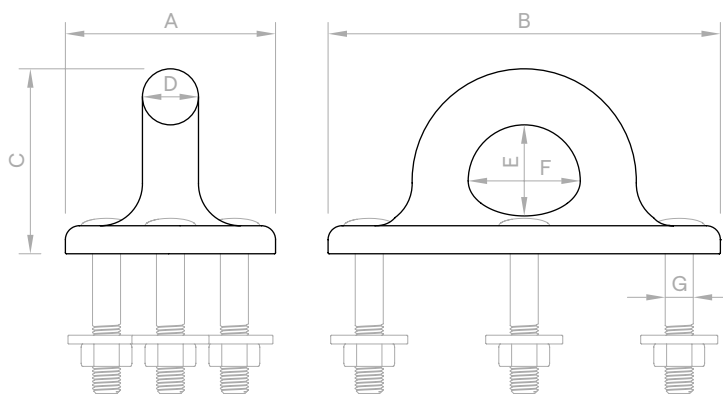

Oval eye with outer bolts.

Materials: bronze (CuAl10Ni);

Finishes: polished bronze or chrome plated;

Part number	A mm	B mm	C mm	D mm	E mm	F mm	G* M
A022	60	112	51	16	27	32	M8 (x4)
A023	90	168	77	24	41	48	M12 (x4)
A024	120	224	102	32	54	64	M20 (x4)

These are all approximate measurements.

* The fixing bolts are not included, they can be supplied if requested.

Note: Images shown are indicative only.

OVAL EYE (EXTENDED)

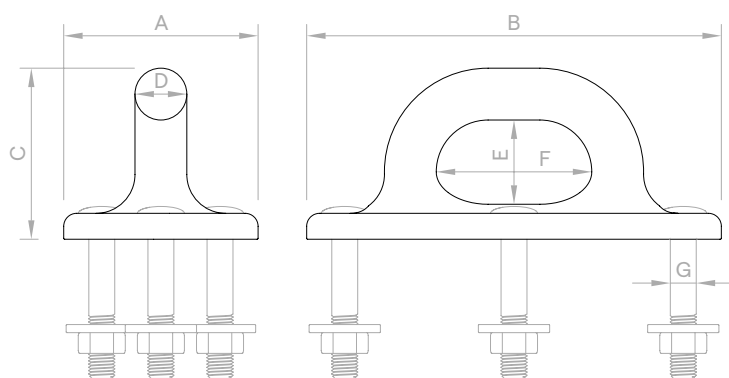

Oval eye with outer bolts.

Materials: bronze (CuAl10Ni);

Finishes: polished bronze or chrome plated;

Part number	A mm	B mm	C mm	D mm	E mm	F mm	G* M
A025	60	128	51	16	27	48	M8 (x4)
A026	90	192	77	24	41	72	M12 (x4)
A027	120	256	102	32	54	96	M20 (x4)

These are all approximate measurements.

* The fixing bolts are not included, they can be supplied if requested.

Note: Images shown are indicative only.

DIAMOND EYE

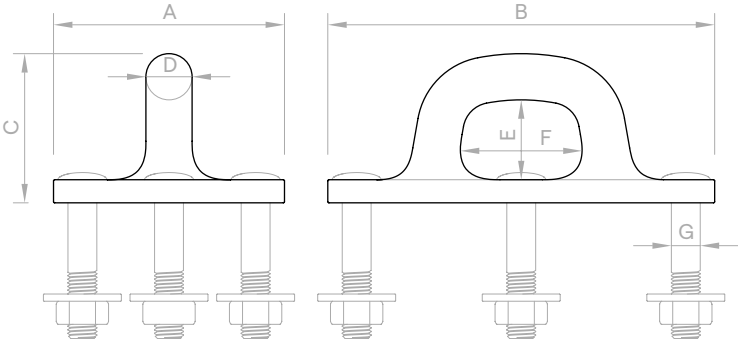

Diamond eye with outer bolts.

Materials: bronze (CuAl10Ni);

Finishes: polished bronze or chrome plated;

Part number	A mm	B mm	C mm	D mm	E mm	F mm	G* M
A028	60	100	38	12	20	32	M8 (x4)
A029	80	134	51	16	27	43	M10 (x4)

These are all approximate measurements.
 * The fixing bolts are not included, they can be supplied if requested.

Note: Images shown are indicative only.

OBLONG EYE

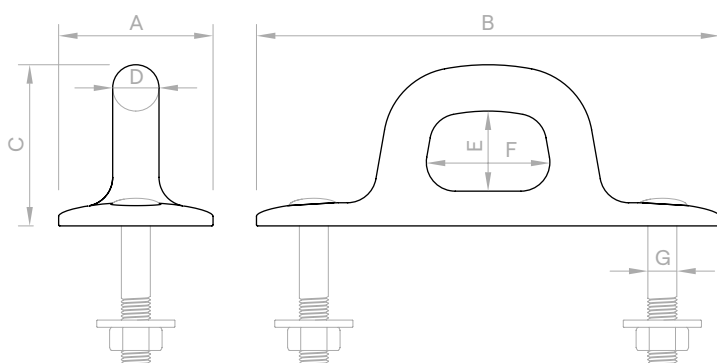

Oblong eye with outer bolts.

Materials: bronze (CuAl10Ni);

Finishes: polished bronze or chrome plated;

Part number	A mm	B mm	C mm	D mm	E mm	F mm	G* M
A030	40	120	41	12	20	32	M8 (x2)
A031	53	160	55	16	27	43	M10 (x2)

These are all approximate measurements.

* The fixing bolts are not included, they can be supplied if requested.

Note: Images shown are indicative only.

ABSOLUTE

Visit us at www.absolute-projects.com
contact@absolute-projects.com | 2021